



COMMERCIAL HOT TUBS

www.HydroTher.com



Designed For

- Spas
- Hotels/Resorts
- Apartments & Condominiums
- Campgrounds
- Health Clubs
- Medical Clinics
- Waterparks

HydroTher Mechanical Equipment Packs



Mechanical Support Systems

Each HydroTher Commercial Hot Tub is available with an optional factory plumbed & water tested Mechanical Support System that is fully labelled and mounted on a water-proof plastic base to save you costly on-site labour and ensure maximum flow rates.

Options

- Deletion of heater
- Hi-Limit Control
- Electronic Countdown Timer
- Emergency Push-Pull Switch
- Audio Visual Beacon Alarm
- Set of 2 Vac Alert SVRS's

For technical specifications, drawings and further information on both pre-plumbed shells and mechanical support systems go to www.HydroTher.com or call the Commercial Sales Division.

Model	Pack	Voltage	Phase	Circulation Pump	Jet Pump	Filter	Heater
H600	HCSP1-240	240	1	1/2 hp	1.5 hp	100 sf	11 kw
	HCSP1-208-230/460	208-230/460	3	3/4 hp	1.5 hp	100 sf	12 kw
	HCSP1-575	575	3	3/4 hp	1.5 hp	100 sf	12 kw
H800	HCSP2-240	240	1	3/4 hp	2 hp	100 sf	11 kw
	HCSP2-208-230/460	208-230/460	3	3/4 hp	2 hp	100 sf	12 kw
	HCSP2-575	575	3	3/4 hp	2 hp	100 sf	12 kw
H1100	HCSP3-240	240	1	3/4 hp	3 hp	150 sf	15 kw
	HCSP3-208-230/460	208-230/460	3	3/4 hp	3 hp	150 sf	15 kw
	HCSP3-575	575	3	3/4 hp	3 hp	150 sf	15 kw
H1200	HCSP4-240	240	1	3/4 hp	3 hp	150 sf	15 kw
	HCSP4-208-230/460	208-230/460	3	3/4 hp	3 hp	150 sf	15 kw
	HCSP4-575	575	3	3/4 hp	3 hp	150 sf	15 kw

Options

- Waterline tile. Choice of Blue, Brown or Gray.
- Underwater LED light. Choice of white or rotating rainbow of colours.
- Wall mountable Chemical Control System to ensure consistently proper chemical settings. Reduces daily testing by staff. Includes canister type chlorinator/brominator, solenoid valve, controller, sensors, rotary probe chambers, piston switch, acid pump, slurry tank.
- To add 2nd chemical pump and slurry tank (for liquid sanitizer use) and delete canister chlorinator/brominator.
- 33" Stainless Steel Safety Entry "P" Shaped Grab Bar. Choice of flanges for installation on wooden decks or with anchors and decorative escutcheons for concrete decks.
- Safety Insulating Hardcovers. Choice of Blue, Brown or Gray.

HydroTher Commercial Hot Tubs

HydroTher Commercial Hot Tubs are the #1 choice of architects, consultants, designers and facility operators. They are VGB compliant and manufactured to withstand the demands of heavy commercial use. Each model conforms to current commercial standards.

- Less expensive than conventional concrete models
- Factory plumbed for quick & inexpensive installation
- Light weight allows upper level installation



"SELF-CLEANING" Bottom Suction Drains

Each HydroTher commercial hot tub features built-in bottom suction grate drains that maximize circulation, eliminate the problem of dirt settling on the floor of the spa and allows total tub drainage without bailing. VGB compliant SDX, 10" diameter high flow safety floor suction fitting, meets ASME A112.19.8 – 2007, ASME A112.19.8a standards.



N.S.F. Approved Skimmer

Each HydroTher commercial hot tub is equipped with a N.S.F. approved skimmer and decorative face plate complete with hair and lint trap that maximizes water flow and surface cleaning as well as a automatic water level control that insures constant proper water levels thereby minimizing staff involvement.



Factory Installed Support Base

Each HydroTher commercial hot tub is equipped with fiberglass coated wood support bracing to spread the weight bearing over a wider area.



Optional Waterline Tile

7" of distinctive shiny glass tile.



Blue



Brown

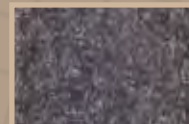

Gray

Tile color swatches may not be exactly as shown

HydroTher H-600C 78"x78"x38"deep / 198 x198 x 96.5 cm

Pre-plumbed shell with 5 large jets, N.S.F. approved skimmer, one floor suction/drain, two side-wall suction, two air controls, water level controller. Seats 5-6 people (some jurisdictions may reduce spa user capacity)



Sizes may vary up to 1/2" or 1.27 cm

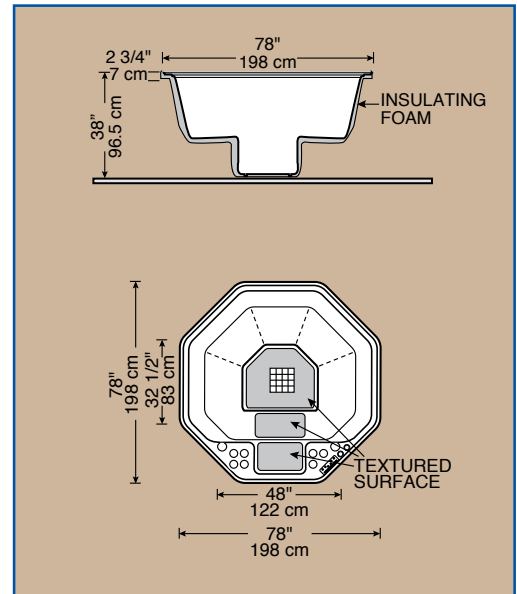

VOLUME: @375 US gallons / 1420 Litres
WEIGHT FULL: 3808 lbs / 1727 Kg
WEIGHT EMPTY: 680 lbs / 310 Kg

HydroTher H-800C 96" Round x 42.5" deep / 244 Round x 108 cm

Pre-plumbed shell with 8 large jets, N.S.F. approved skimmer, two floor suction/drains, two air controls, water level controller. Seats 7-8 people (some jurisdictions may reduce spa user capacity)



Sizes may vary up to 1/2" or 1.27 cm

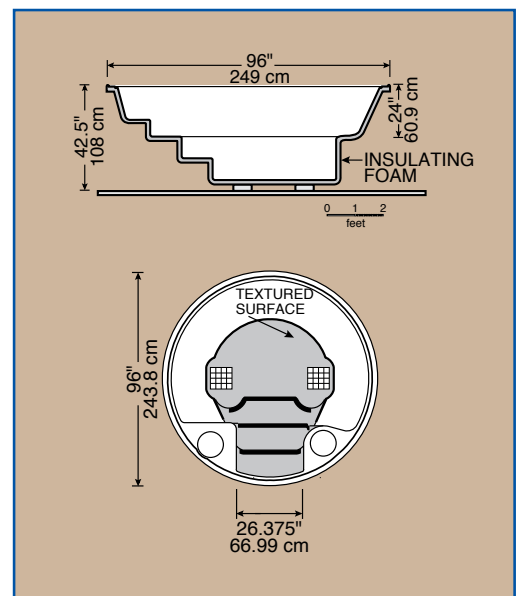

VOLUME: @450 US gallons / 1704 Litres
WEIGHT FULL: 4553 lbs / 2065 kg
WEIGHT EMPTY: 800 lbs / 363 kg

HydroTher H-1100C 120" x 92" x 42.5" / 305 x 233 x 108 cm

Pre-plumbed shell with 7 large jets, 4 medium jets, N.S.F. approved skimmer, two floor suction/drains, two air controls, water level controller. Seats 9-11 people (some jurisdictions may reduce spa user capacity)



Sizes may vary up to 1/2" or 1.27 cm

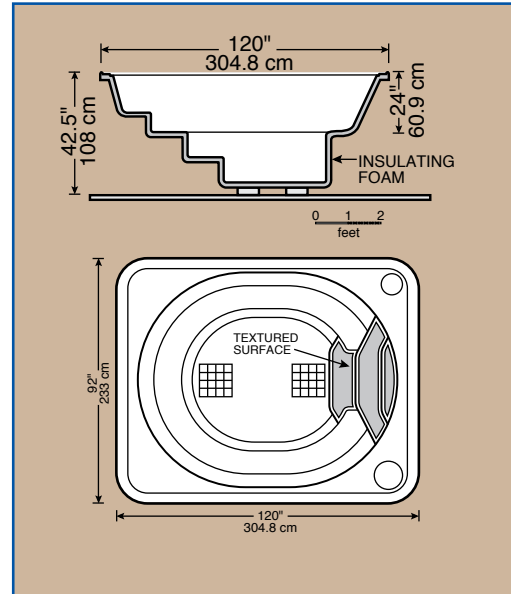

VOLUME: 650 US gallons / 2457 Litres

WEIGHT FULL: 6371 lbs / 2890 kg

WEIGHT EMPTY: 950 lbs / 431 kg

HydroTher H-1200C 144" x 92" x 42.5" / 366 x 233 x 108 cm

Pre-plumbed shell with 9 large jets, 4 medium jets, N.S.F. approved skimmer(s), two floor suction/drains, two air controls, water level controller. Seats 12-13 people (some jurisdictions may reduce spa user capacity)



Sizes may vary up to 1/2" or 1.27 cm

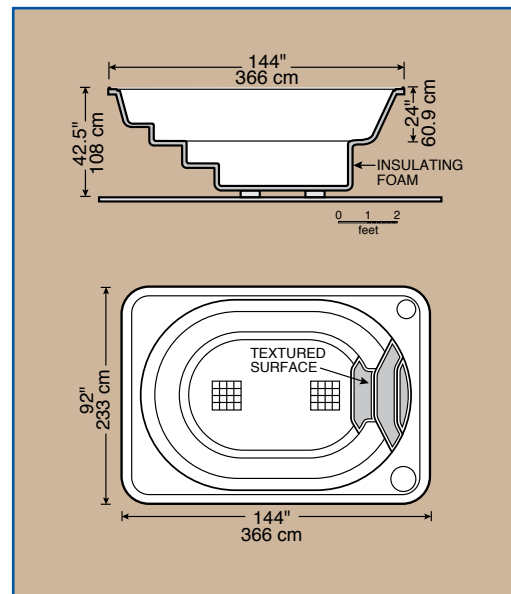

VOLUME: 840 US gallons / 3180 Litres

WEIGHT FULL: 8055 lbs / 3654 kg

WEIGHT EMPTY: 1050 lbs / 476 kg



1-800-891-5811

www.HydroTher.com
info@HydroTher.com

Built By a Company You Can Trust

HydroTher is a division of PPL Aquatic, Fitness & Spa Group, a group of companies that has been specializing in the commercial pool and hot tub industry since 1970.

Recognized for Excellence in Design



Commercial Guarantee

HydroTher commercial units are backed by a five (5) year warranty on the shell structure and acrylic surface, two (2) years on the plumbing and mechanical equipment and one (1) year on the labour and accessories.

Your Local HydroTher Commercial Dealer is:



Manufactured in Canada

www.HydroTher.com

Printed in Canada